

# Operating Instructions

## — Piston Compressor

— AIRBOY KITT 90

— AIRBOY 262 E



AIRBOY KITT 90



AIRBOY 262 E

AIRBOY-SERIES

## Imprint

### Product identification

Piston Compressor	Item number
AIRBOY KITT 90	2001237
AIRBOY 262 E	2001247

### Manufacturer

AIRCRAFT  
Kompressorenbau und Maschinenhandel GmbH  
Gewerbestraße Ost 6

Phone: 0043 (0) 7752 70 929 - 0  
Fax: 0043 (0) 7752 70 929 - 99  
E-Mail: info@aircraft.at  
Internet: www.aircraft.at

### Sales Germany

AIRCRAFT - Stürmer Maschinen GmbH  
Dr.-Robert-Pfleger-Straße 26  
D-96103 Hallstadt/Bamberg

Fax: 0049 (0) 951 - 96555-55  
E-Mail: info@aircraft-kompressoren.de  
Internet: www.aircraft-kompressoren.com

### Indications regarding the operating instructions

#### Original instructions

Edition: 02.03.2021  
Version: 1.05  
Language: English  
Author: MS/ES

### Indications regarding the copyright

Copyright © 2021 AIRCRAFT Kompressorenbau und Maschinenhandel GmbH, Hohenzell, Austria.

The contents of these operating instructions is the sole property of the company AIRCRAFT Kompressorenbau und Maschinenhandel GmbH.

Passing on as well as copying of this document, the use and distribution of its content are prohibited if not explicitly permitted. Contraventions are liable to compensation.

Subject to technical modifications and error.

## Content

<b>1 Introduction .....</b>	<b>3</b>
1.1 Copyright .....	3
1.2 Customer service .....	3
1.3 Limitation of liability .....	3
<b>2 Safety .....</b>	<b>3</b>
2.1 Symbol explanation .....	4
2.2 Personal protective equipment .....	4
2.3 General safety notes .....	5
2.4 Verification of operational safety .....	5
2.5 Safety labels on the compressor .....	5
2.6 Safety devices .....	6
<b>3 Intended use .....</b>	<b>6</b>
<b>4 Technical Data .....</b>	<b>7</b>
4.1 Type plate .....	7
<b>5 Transport, Packaging and Storage .....</b>	<b>8</b>
5.1 Delivery and Transport .....	8
5.2 Packaging .....	8
5.3 Storage .....	8
5.4 Information about technical support .....	8
<b>6 Description of device .....</b>	<b>8</b>
<b>7 Before commissioning .....</b>	<b>8</b>
<b>8 Operation .....</b>	<b>9</b>
8.1 Motor protection .....	9
8.2 Set up .....	9
8.3 Switch on .....	9
8.4 Setting the working pressure .....	10
8.5 Air pressure switch .....	10
<b>9 Maintenance, care and servicing/repair .....</b>	<b>11</b>
9.1 Maintenance and care .....	11
9.2 Functional test of the safety valve .....	12
9.3 Repair .....	13
9.4 Troubleshooting .....	13
<b>10 Disposal, recycling of used devices .....</b>	<b>14</b>
10.1 Decommissioning .....	14
10.2 Disposal of lubricants .....	14
<b>11 Spare parts .....</b>	<b>14</b>
11.1 Ordering spare parts .....	14
11.2 Spare parts drawings AIRBOY KITT 90 .....	15
11.3 Spare parts drawings AIRBOY 262 E .....	17
<b>12 EU Declaration of Conformity .....</b>	<b>19</b>

# 1 Introduction

You have made a good choice by purchasing the compressor made by AIRCRAFT.

**Please thoroughly read the operating instructions before commissioning.**

It informs you about the proper commissioning, the intended use as well as the safe and efficient operation and maintenance of your compressor.

The operating instructions are part of the compressor. Always keep it at the place of use of the compressor. Furthermore, the local accident prevention regulations and the general safety notes are applicable for the field of application of the compressor.

The illustrations in these operating instructions serve the general comprehension and may deviate from the actual type.

## 1.1 Copyright

The contents of these instructions are copyright. Their application is admissible in the frame of the compressor utilisation. An application beyond the described application is not allowed without written approval of the manufacturer.

For the protection of our products, we shall register trademark, patent and design rights, as this is possible in individual cases. We strongly oppose any infringement of our intellectual property.

## 1.2 Customer service

Please contact your dealer if you have questions on your compressor or if you need technical advice. They will help you with specialist information and expert advice.

### **Austria:**

AIRCRAFT Kompressorenbau und Maschinenhandel GmbH  
Gewerbestraße Ost 6  
A-4921 Hohenzell

Phone: 0043 (0) 7752 70 929-0  
Fax: 0043 (0) 7752 70 929-99

Email: [info@aircraft.at](mailto:info@aircraft.at)  
Internet: [www.aircraft.at](http://www.aircraft.at)

### **Germany:**

Stürmer Maschinen GmbH  
Dr.-Robert-Pfleger-Str. 26  
D-96103 Hallstadt

### **Repair service:**

Fax: 0049 (0)951 96555-111  
E-Mail: [service@stuermer-maschinen.de](mailto:service@stuermer-maschinen.de)

### **Spare part orders:**

Fax: 0049 (0)951 96555-119  
Email: [ersatzteile@stuermer-maschinen.de](mailto:ersatzteile@stuermer-maschinen.de)

We are always interested in valuable experience and knowledge gained from using the application, which then could be shared and be valuable to develop our products even further.

## 1.3 Limitation of liability

All information and notes in these operating instructions were summarised taking the applicable standards and rules, the state-of-the-art and our long-term knowledge and experiences into consideration.

In the following cases the manufacturer is not liable for damages:

- Non-observance of the operating instructions,
- Inappropriate use
- Use of untrained staff,
- Unauthorised modifications
- Technical changes,
- Use of not allowed spare parts.

The actual scope of delivery may deviate from the explanations and presentations described here in case of special models, when using additional ordering options or due to latest technical modifications.

The obligations agreed in the delivery contract, the general terms and conditions as well as the delivery conditions of the manufacturer and the legal regulations at the time of the conclusion of the contract are applicable.

# 2 Safety

This paragraph will give you an overview of all important safety packages for the protection of the people using it well as for a safe and undisturbed operation. Other task-based safety notes are included in the individual chapters.

## 2.1 Symbol explanation

### Safety instructions

The safety notes in these operating instructions are highlighted by symbols. The safety notes are introduced by signal words which express the concern of the risk.



#### **DANGER!**

This combination of symbol and signal words indicates an imminently dangerous situation which may lead to death or severe injuries if they are not avoided.



#### **WARNING!**

This combination of symbol and signal words indicates a possibly dangerous situation which may lead to death or severe injuries if they are not avoided.



#### **CAUTION!**

This combination of symbol and signal words indicates a possibly dangerous situation which may lead to minor or light injuries if they are not avoided.



#### **ATTENTION!**

This combination of symbol and signal words indicates a possibly dangerous situation which may lead to property and environmental damages if they are not avoided.



#### **NOTE!**

This combination of symbol and signal words indicates a possibly dangerous situation which may lead to property and environmental damages if they are not avoided.

### Tips and recommendations



#### **Tips and recommendations**

This symbol highlights useful tips and recommendations as well as information for an efficient and trouble-free operation.

It is necessary to observe the safety notes written in these operating instructions in order to reduce the risk of personal injuries and damages to property.

## 2.2 Personal protective equipment

The personal protective equipment serves to protect persons against impairments of safety and health while working. The staff has to wear personal protective equipment while performing different works on and with the device which are indicated in the individual paragraphs of these instructions.

The personal protective equipment is explained in the following paragraph:



#### **Hearing protection**

The hearing protection protects the ears against damages of hearing due to noise.



#### **Eye protection**

The protective goggles protect the eyes against parts flying off and splashes of liquids.



#### **Breathing protection**

The dust mask protects from coarse dust particles.



#### **Protective gloves**

The protective gloves serve to protect the hands against sharp components as well as against friction, abrasions or deep injuries.



#### **Safety boots**

The safety boots protect the feet against crushes, falling parts and slipping over on slippery underground.



#### **Protective clothes**

The protective clothes are tight clothes of little tensile strength.



#### **Head protection**

The industrial helmet protects the head against falling objects and collisions with fixed objects.

## 2.3 General safety notes

- Observe the guidelines and accident prevention regulations of the trade association for the work with compressors and pneumatic tools.
- The compressor must not be operated in rain or in a wet or moist environment.



### CAUTION! RISK OF INJURY

- Never direct compressed air to persons or animals.
- Grab the end of the compressed air hose with your hand before opening the quick coupling in order to prevent the tool from flying off by the pressure.
- Allow the compressor to cool down prior to maintenance work.

## 2.4 Verification of operational safety

The pressure tank of the compressor is submitted to inspection. The manufacturer submitted the pressure tank to an inspection according to the EC Directive 2014/29 EG in conjunction with the EC type examination according to article 10 as well as according to EN 286-1. A copy of this type examination certification and/or declaration of conformity is included in the scope of delivery of every compressor.

The operating company must have re-inspected the individual components to be inspected by an expert or by a "qualified person" in the prescribed intervals. The operating regulations for this may differ in the individual EC countries.

### Regulations for compressed air tanks in Germany

#### Inspection periods

The given inspection periods are maximum values. They should be verified by the risk assessment/valuation of employer of the operating company. No delays are admissible for this. It is only possible to shorten the period.

The product of pressure and volume depends on the inspection periods. For this, the maximum admissible pressure (PS) must be multiplied with the pressure tank volume (V).

Example:

Pressure tank = 50 l ; max. admissible pressure = 10 bar  
 $50 \text{ l} \times 10 \text{ bar} = 500$

Check	Inspection periods	Inspection organisation
Prior to commissioning/positioning	PS xV $\leq$ 200	Qualified person
	with type examination certificate PS xV $\leq$ 1000	Qualified person
	PS xV $\geq$ 200	Approved inspection agency
Exterior inspection **	Once a year/every two years < 1.000	Qualified person

Check	Inspection periods	Inspection organisation
Interior inspection**	Once every 5 years for PS xV $\leq$ 1000	Qualified person
	*Once every 5 years for PS xV $\geq$ 1000	Approved inspection agency
Strength test **	Once every 10 years PS xV $\leq$ 1000	Qualified person
	*Once every 10 years PS xV $\geq$ 1000	Approved inspection agency

\*The employer must communicate the relevant inspection periods to the responsible authority within 6 months after commissioning the installation (par. 15 BetrSichV).

\*\* External tests can be omitted: a) for pressure tanks according to point 2.2 (letter a), unless they are fire-heated, heated exhaust gas or electrically heated, and

b) in the case of simple pressure tanks according to BetrSichV point 2.2 letter d. The deadline of the strength test may be extended to 15 years if it is shown in the external or internal test that the machine can be safely operated. The confirmation must be shown in the documentation of the risk assessment. Table according to BetrSichV (State: 2017-03-29).

## 2.5 Safety labels on the compressor

Damaged or missing safety symbols on the compressor can lead to malfunctions and property damage. The safety symbols attached to the machine must not be removed. Damaged safety symbols must be replaced immediately.

#### Please note the following:

The instructions of the safety label on the compressor must be obeyed under all circumstances. If fading or damage to the safety labels occurs in the course of the service life of the machine, new labels must be attached immediately.

From the moment the signs are not immediately recognizable and comprehensible, the machine must be taken out of service until the new signs are fitted.

The following safety symbols are attached to the compressor:



Attention! Mains voltage



Caution! Danger of burns



Attention! Automatic startup



Read instruction manual

Fig. 1: Safety labels

## 2.6 Safety devices

### Safety valve

Depending on the model, two different versions of safety valves can be installed..

#### Version A (Safety valve with ring)



Fig. 2: Safety valve, Version A

#### Version B (Safety valve with collar)

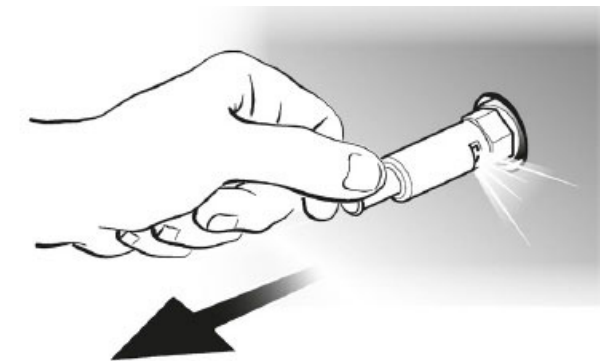

Fig. 3: Safety valve, Version B

The safety valve is located on the pressure switch.

It is set to the maximum permissible pressure in the pressure vessel.

If the maximum permissible pressure is exceeded, the safety valve opens automatically and releases air until the pressure is back within the permissible range.

After the safety valve has been triggered, the operator must switch off the compressor and request a check by maintenance personnel.



#### ATTENTION!

The safety valve must not be adjusted!

### Motor protection

The compressors are equipped with a motor protection switch (on the left at the back of the motor) that automatically cuts off the power supply in the event of an overload. If the motor protection switch trips a forced shutdown, leave the compressor in this state and wait a few minutes before restarting the compressor at the on/off switch. If the circuit breaker trips again, disconnect the power supply and contact an authorised service centre.

## 3 Intended use

The compressor is used to operate pneumatic tools and related pneumatic controls and systems. It is designed to suck in and compress clean and unencumbered ambient air. The ambient air must not contain any aggressive or combustible admixtures.

In the case of a purpose other than the intended use, the written approval must first be obtained from the manufacturer.

Proper use also includes compliance with all information in this manual. Any use beyond the intended use or otherwise is considered misuse.



#### DANGER!

Airboy compressors are not explosion-proof as standard and must not be operated in hazardous areas!



#### NOTE!

The improper use of the compressors and the disregard of the safety regulations or the operating instructions exclude a liability of the manufacturer for resulting damage to persons or objects and cause the warranty to expire!





**DANGER!**

Unauthorized modifications or changes, especially those that affect the safety of the machine and the machine operator, are generally prohibited. Technical changes, alterations and extensions made by the user on the machine can invalidate the CE conformity of the machine and are the responsibility of the operator.

The AIRBOY KITT 90 and AIRBOY 262 E compressors are an electric motor driven reciprocating compressor with attached compressed air storage tank intended for sale and operation in the EU and European geographical area.



**WARNING!**

**Danger in case of misuse!**

Misuse of the compressor can lead to dangerous situations.

- Operate the compressor only in the power range listed in the technical data.
- Never bypass or override the safety devices.
- Only operate the compressor in a technically perfect condition.

For constructional and technical changes to the device, the company AIRCRAFT Kompressorenbau und Maschinenhandel GmbH assumes no liability.

Claims of any kind due to damage due to improper use are excluded.

## 4 Technical Data

Technical Data	AIRBOY KITT 90	AIRBOY 262 E
Compressor system	HOS	HOS
Suction capacity approx.	85 l/min	250 l/min
Filling capacity at 6 bar approx.	49 l/min	155 l/min
Max. pressure	15 bar	10 bar
Tank capacity	2,4 l	2,4 l
Cylinders/stages	1 /1	1 /1
Speed	1420 1/min	2850 1/min
Motor power	0,6 kW / 230 V	1,5 kW / 230 V
Weight	21 kg	23 kg
Dimension (LxWxH)	510 x 270 x 400 mm	555 x 318 x 430 mm
Sound power level L <sub>WA</sub>	85 dB(A)	97 dB(A)

### 4.1 Type plate

The type plate (at the back left of the pressure vessel) shows the following information:

Type designation

Maximum flow / Suction

Power of the electric motor

Connection data of the compressor

Construction year

Mounted compressor type

Maximum pressure of the compressor

Fabrication number = serial number



<b>1</b>	
Höchstvolumenstrom:	Höchstdrehzahl:
Behälterinhalt :	Höchstdruck :
Motor :	Tmin/Tmax:
Anschluß : 50Hz	Art.Nr.:
Baujahr :	Fabr. Nr.:
Verdichter:	
1 2 3 4 5 6 7 8 9 10 11 12	
  	
9 006248 010529	

Fig. 4: Type plate

## 5 Transport, Packaging and Storage

### 5.1 Delivery and Transport

#### Delivery

Check the compressor after delivery for visible transport damage. If the device shows damage, it must be reported immediately to the transport company or the dealer.

Check that the compressor is complete and that the supplied parts are present.

#### Transport



#### NOTE!

Oil may leak during transport of the device. Secure the device accordingly and take precautionary measures against possible environmental pollution.

The compressor may only be transported in upright position and with the motor switched off.

### 5.2 Packaging

Keep the packaging for a possible move, but at least during the warranty period.

All used packaging materials and packaging aids of the compressor are recyclable and generally need to be transported to the material recycling.

Crush the packaging material made of cardboard and supply it to the waste paper collection.

The films are made of polyethylene (PE) and the upholstery parts are made of polystyrene (PS). These materials have to be delivered to a recycling station of the responsible dumping company.

### 5.3 Storage

The compressor must be stored thoroughly cleaned in a dry, clean and frost-free environment.

### 5.4 Information about technical support

Repairs under warranty may only be performed by technicians authorized by us. Use only original spare parts.

For inquiries or orders, please always state the TYPE DESIGNATION, the YEAR OF MANUFACTURE and the PART NUMBER of your compressor. All information can be found on the nameplate, which is attached to the compressor.

## 6 Description of device



Fig. 5: AIRBOY KITT 90

- 1 ON/OFF switch (upon pressure switch)
- 2 Reducing valve
- 3 Tank pressure manometer
- 4 Working pressure manometer
- 5 Coupling for compressed air extraction
- 6 Condensate drain
- 7 Check valve
- 8 Stands
- 9 Oil drain screw
- 10 Tank
- 11 Oil dipstick
- 12 Air suction filter

## 7 Before commissioning

Remove the plug from the motor housing cover and insert the dipstick.

Remove the plug from the motor housing and screw on the filter, if not already fitted.



#### DANGER!

Check the safety valve for proper function by pulling the ring or collar outwards and thereby opening the safety valve (the pressure vessel must be under pressure).



## 8 Operation



### ATTENTION!

The compressor may only be operated in an admissible temperature range of +5° C to +35 °C!



### NOTE!

The following must be observed prior to commissioning.

- The safety devices as well as the protective covers must be in good working order.
- The mains voltage must correspond to the voltage indications on the type plate.
- The ON/OFF switch must be set to position "0", "OFF".



### DANGER!

The device may only be operated in a technically perfect condition. Any faults must be eliminated immediately.

Check the safety valve for proper operation by pulling the ring outwards to open the safety valve (The Pressure vessel must be under pressure).

### 8.1 Motor protection

The compressor is equipped with a motor protection switch (at the rear side of the motor at the left), which automatically interrupts the power supply in case of overload. If the motor protection switch triggers a forced shutdown, leave the compressor in this condition for some minutes, before you actuate the motor protection switch and switch the compressor on again at the ON/OFF switch. If the protection switch should trigger again, set the ON/OFF switch to OFF, disconnect the compressor from the power supply and contact the authorised customer service.

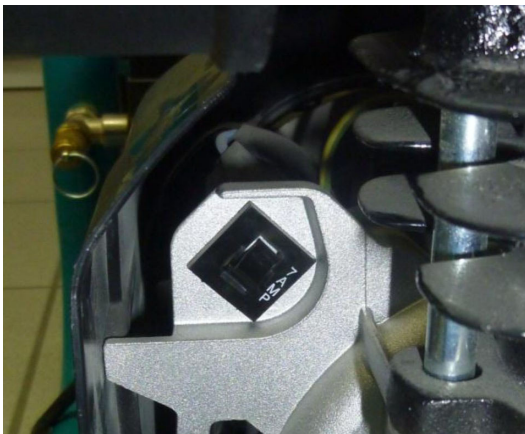

Fig. 6: Motor protection switch

### 8.2 Set up

Use the compressor only on flat surfaces. If it is unavoidable, a possible incline must not exceed 15 °.

Always place the compressor at least 50 cm away from any obstruction that could obstruct the flow of air and thus cooling.

Check that the mains voltage at the place of use of the compressor corresponds to the voltage indicated on the type plate.

### 8.3 Switch on

Step 1: Check the oil level. The oil level must be between the maximum and minimum values on the dipstick. If necessary, add oil.

Step 2: Check whether the mains voltage corresponds to the voltage indicated on the nameplate. Connect the compressor to the power supply.

Step 3: Start the device with the on / off switch located on the pressure switch.

Step 4: When starting the compressor for the first time, run the compressor for approximately ten minutes with the drainage (6) (Fig. 5) open.

Step 5: Close the drain and check if the compressor is charging the container and at  $P_{max}$  stops (maximum pressure, indicated by the pressure gauge (3) (Fig. 5).

The on / off switch releases the function of the pressure switch. The pressure switch switches the compressor on or off depending on the tank pressure reached. The compressor operates automatically, stops when the maximum pressure is reached, and restarts when the switch-on pressure is reached.

### 8.4 Setting the working pressure



**ATTENTION!**

The maximum pressure of the connected tool must not be exceeded.

The working pressure adjustment must be performed with connected and running tool in order to be able to adjust the actually required working pressure.

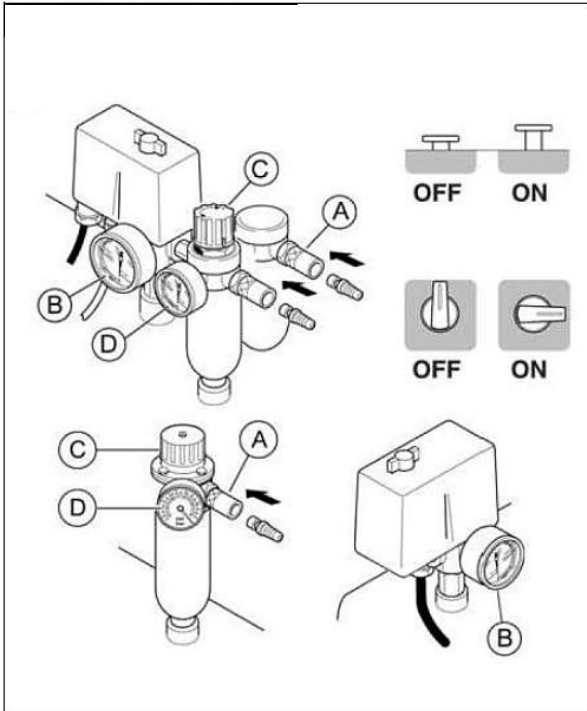

Fig. 7: Setting the working pressure

The working pressure is set at the filter pressure regulator **C** (Fig. 7) (turn or lift the rotating cap, set the desired pressure and press the rotating cap downward and latch it) and can be read at the manometer **D**. The compressed air is extracted at the coupling **A**.

We recommend to set the pressure value back to zero after the use of the compressor. If you use pneumatic tools, always check the optimum application pressure of the accessory.

### 8.5 Air pressure switch



**ATTENTION!**

Always switch off the compressor at the ON/OFF switch prior to this adjustment work and disconnect it from the electric power supply.

Release the pressure switch prior to the pressure adjustment. Pressure adjustment is only possible at the installed pressure switch with the compressor under pressure.

Due to thermal interaction (cold, warm) and compressor vibrations it may happen that the pressure switch adjustment changes.

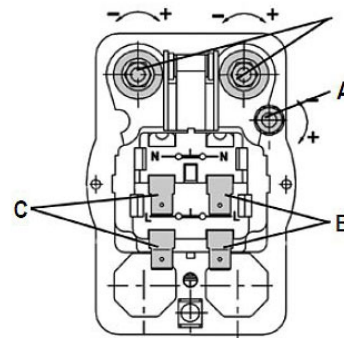

Fig. 8: Pressure switch MDR 2

- A Pressure difference
- B Motor
- C Mains

## 9 Maintenance, care and servicing/ repair

### 9.1 Maintenance and care



#### DANGER!

All works on electric and pneumatic systems may only be performed by specialist personnel who has received the relevant training and who is aware of the associated hazards.



#### Use protective gloves!



#### Wear protective clothes!

Step 1: Prior to performing any maintenance work, switch the compressor off, pull the mains plug from the power socket and discharge the compressed air completely from the tank.

#### After the first 50 hours:

Step 2: Check whether all screws are tight, in particular the cylinder head and frame screws. With the compressor at operating temperature, tighten the cylinder screws.

Step 3: Change the oil. The compressor must be warm for this.

#### Once a week:

Step 2: Check the oil level and refill oil if necessary. Use only oil of the same type. Never exceed the maximum filling amount. Only use oil of the same type!

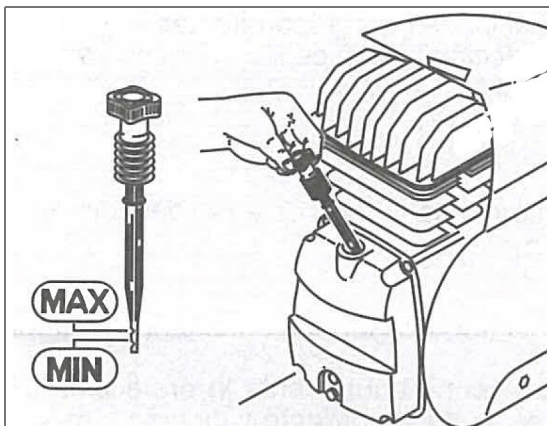

Fig. 9: Check oil level

Step 3: Drain the condensed water by opening the valve below the tank (6, Fig. 5). Close the valve again as soon as only air flows out without condensed water. Protective gloves must be worn for this. A flat container is recommended to catch the condensed water.



#### Use protective gloves!



#### ATTENTION!

The condensate which flows out contains oil and must not enter the public sewer system!

Step 4: You can separate oil and water with an appropriate oil separator. You can discharge the clean water into the public sewer system. The oil will be collected in a separate container and must be disposed of properly. Please observe the drainage regulations of your relevant municipality! We will gladly advise you if you have any relevant questions.

#### Once per month (or more frequently, if the device is operated under heavy load and/or in a dusty environment):

Step 2: Remove the suction filter and change it (if damaged) or clean the filter element.

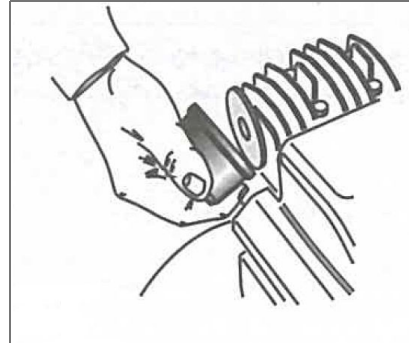

Fig. 10: Air filter

Filter element made of PAPER: Blow with compressed air from the inside to the outside.

Filter element made of FOAM: Wash with detergent, rinse and allow to dry completely.

Filter element made of METAL: Rinse with non-greasy solvent and blow through with compressed air.



#### ATTENTION!

Never operate the compressor without suction filter!

**Once every 6 months:**

Step 2: Change the oil (the compressor must be warm for this).  
Remove the oil filling screw or the plug or oil dipstick, screw out the oil drain screw (A) (Fig. 11) and collect the used oil in a corresponding container.

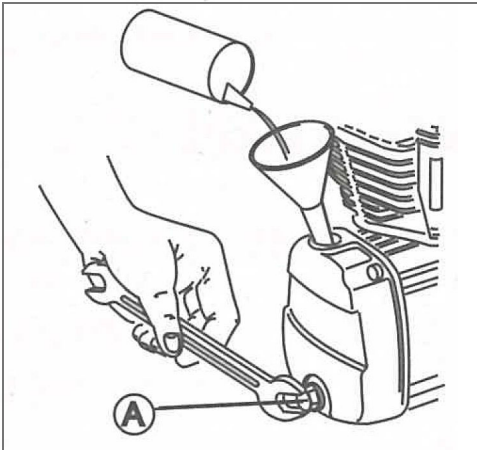

Fig. 11: Oil change

Step 3: Insert and tighten the oil drain screw and fill in new oil up to the maximum level. Insert the oil filling screw or the oil dipstick or the plug again.  
**Original Equipment Oil: Mineral Oil 20W-30 (Compressors Oil Part No. 2500012)**



**ATTENTION!**

Never mix different oil types!

Step 4: Open and close the safety valve (S, Fig. 12), beside the pressure switch) by pulling the ring (the tank must be under pressure). Check the safety valve for flawless function: It must open at overpressure.

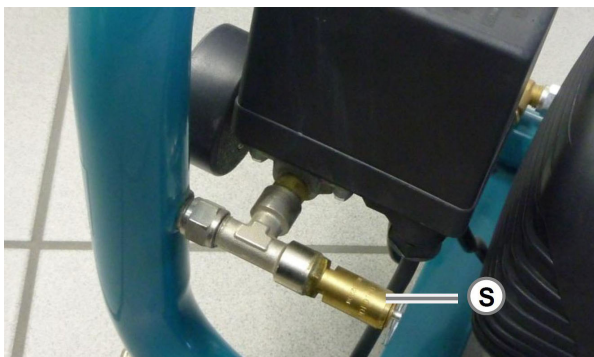

Fig. 12: Safety valve

Step 5: Thoroughly clean all components which have ribs or lamellae.

**Once every two years:**

Step 2: Examine the check valve and change the sealing element D (Fig. 11) if necessary.

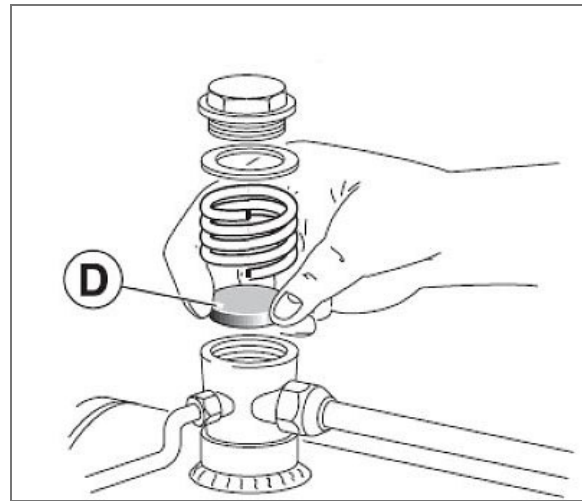

Fig. 13: Check valve

freewheel valve.

**9.2 Functional test of the safety valve**

The safety valve must be operated regularly to ensure that it functions properly when required.

**Version A (safety valve with ring)**

Every 6 months:  
Open the safety valve (Fig. 14) by pulling the ring briefly outwards until compressed air escapes, and release it again (the pressure vessel must be under pressure).



Fig. 14: Safety valve, Version A

**Version B (Safety valve with collar)**

Every 6 months:

Open the safety valve (Fig. 15) by briefly pulling the clamp outwards until compressed air escapes and then releasing it again (the pressure vessel must be under pressure).

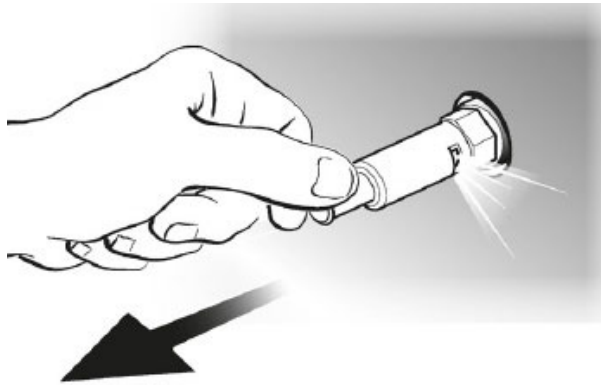

Fig. 15: Safety valve, Version B

**9.3 Repair**



**DANGER!**

Maintenance work may only be carried out by a specialist workshop or by trained specialists. Maintenance work on the electrical equipment may only be carried out by electricians or under the supervision and direction of a qualified electrician.

The company Aircraft Kompressoren assumes no liability and warranty for damage and malfunction as a result of non-compliance with this manual. Use only proper and suitable tools, original spare parts or serial parts expressly approved by Aircraft Compressors for repairs.

**9.4 Troubleshooting**

Malfunction	Remedy
The compressor does not start	The pressure switch is in the off state. Switch on the compressor at the pressure switch.
The compressor does not reach the cut-off pressure.	Seals on the compressor or check valve leaking. Replace seals.
The compressor shuts off.	No disturbance, the reservoir is filled, the maximum pressure has been reached.
The compressor stops and does not start again.	The motor protection switch has tripped. Leave the compressor switched off. After a few minutes, turn the power on again. If the motor protection switch triggers again after the restart, please contact customer service.
The compressor runs only briefly until the switch-off pressure has been reached and switches on again after a short time.	Switching distance of the pressure switch too low. Increase operating distance. Very much condensation in the pressure vessel. Drain condensation
The pressure in the container drops.	Check all connections and tighten if necessary. If the problem persists, contact customer service.
Air leakage at the valve of the pressure switch with the compressor switched off.	Clean the seat of the check valve very thoroughly. If necessary, replace the sealing element.
The safety valve blows off.	Cut-off pressure at the pressure switch is set too high. Reduce cut-off pressure at the pressure switch. Safety valve defective. Replace safety valve.
The compressor does not charge and heats up too much.	The cylinder head gasket or valve lamella is damaged. Stop the compressor immediately and contact Customer Service. Air filter dirty. Clean the air filter.
The compressor is very loud and makes rhythmic, metallic beats.	The sliding bush or the bearing bush is seized. Stop the compressor immediately and contact Customer Service.
The compressor does not stop when max. P <sub>max</sub> Pressure) is reached; the safety valve starts.	The pressure switch may be out of adjustment (see section "Pressure switch"). If the problem persists after performing maintenance, please contact Customer Service.
The compressor shuts off too soon.	



## 10 Disposal, recycling of used devices

For environmental benefits it is necessary to ensure that all components of the device are only disposed of by the provided and allowed means.

### 10.1 Decommissioning

Immediately decommission used compressors in order to avoid later misuse and endangering of the environment or of persons.

- Dispose of all environmentally hazardous operating materials from the used compressor.
- If required, disassemble the compressor into easy-to-handle and usable components and parts.
- Supply the components and operating materials to the provided disposal routes.

### 10.2 Disposal of lubricants

The manufacturer of the lubricant makes the disposal instructions for the used lubricants available. If applicable, ask for the product-specific data sheets.

## 11 Spare parts



### DANGER!

#### Risk of injury due to the use of wrong spare parts!

Dangers may result for the user and damages as well as malfunctions may be caused by using wrong or damaged spare parts.

- Only use original spare parts of the manufacturer or spare parts admitted by the manufacturer.
- Always contact the manufacturer in case of uncertainties.



### Tips and recommendations

The manufacturer's warranty will become null and void if non admitted spare parts are being used

## 11.1 Ordering spare parts

The spare parts may be purchased with the authorised dealer or directly with the manufacturer. Please find the corresponding contact data in Chapter 1.2 Customer service.

Indicate the following basic information for requests or orders of spare parts:

- Type of device
- Item No.
- Position No.
- Year of construction:
- Quantity
- Required mode of dispatch (mail, freight, sea, air, express)
- Address of dispatch

Spare part orders which do not include the above indications may not be taken into consideration. If the indications regarding the mode of dispatch are missing, the product is dispatched at the discretion of the supplier.

You will find indications regarding the device type, item No. and year of construction on the type plate which is fixed on the compressor.

### Example

The condensate drain valve for compressor Maschinentyp must be ordered. The condensate drain has the position number 107 in the spare parts drawing No 2.

When ordering spare parts, send a copy of the spare parts drawing (2) with the marked component (drain valve) and marked position number (107) to the authorised dealer or the spare parts department and provide the following information:

- Type of device: **Maschinentyp**
- Item number: **2001237**
- Spare parts drawing number: **2**
- Position No.: **107**

### Item number of your device:

Piston Compressor AIRBOY KITT 90: **2001237**  
Compressor system: **HOS**

Piston Compressor AIRBOY 262 E: **2001247**  
Compressor system: **MK 265**

The following drawings should help to identify necessary spare parts in case of service





Spare parts drawing 2: Housing

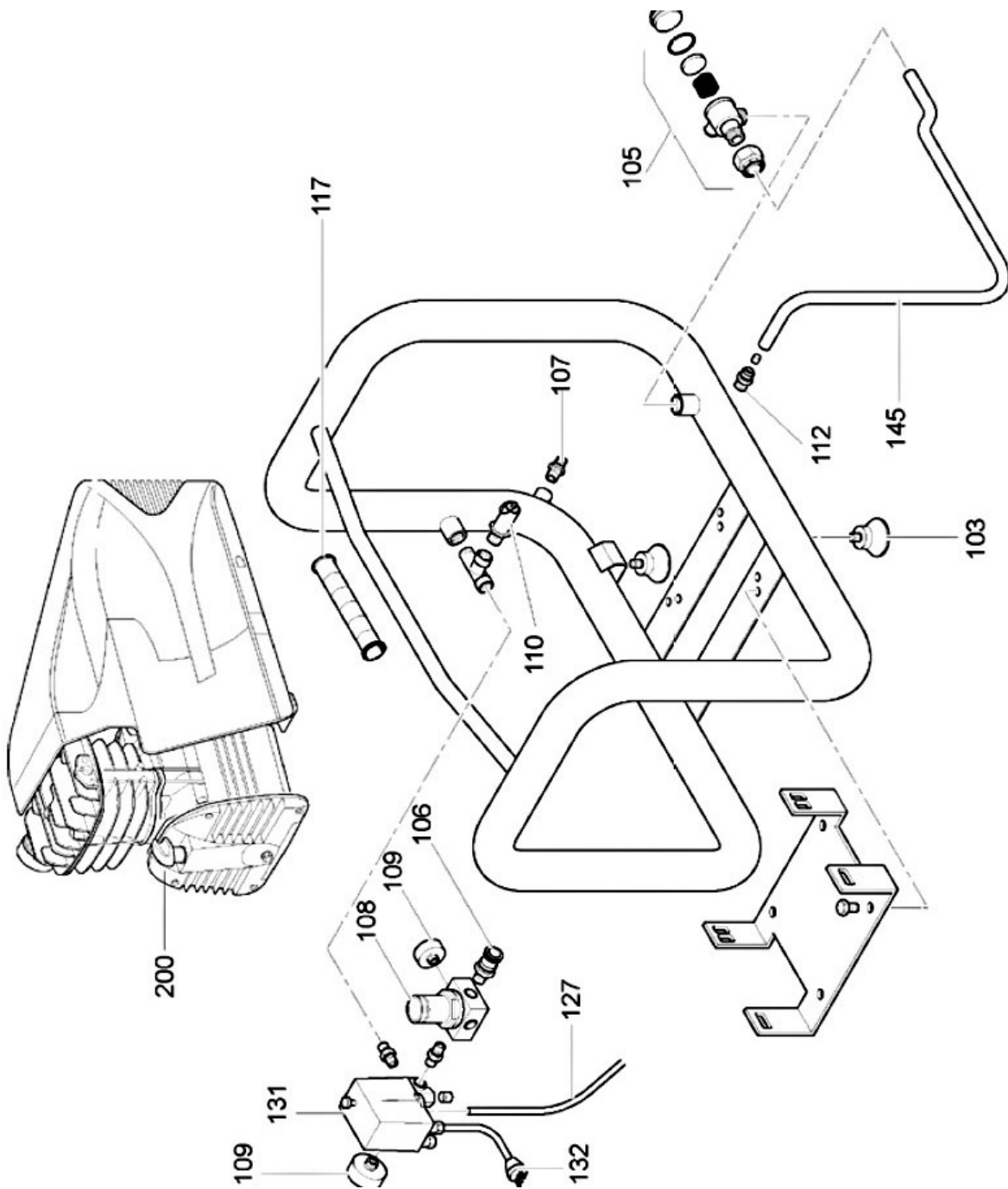

Fig. 17: Spare parts Housing

### 11.3 Spare parts drawings AIRBOY 262 E

#### Spare parts drawing 1: Compressor MK 265

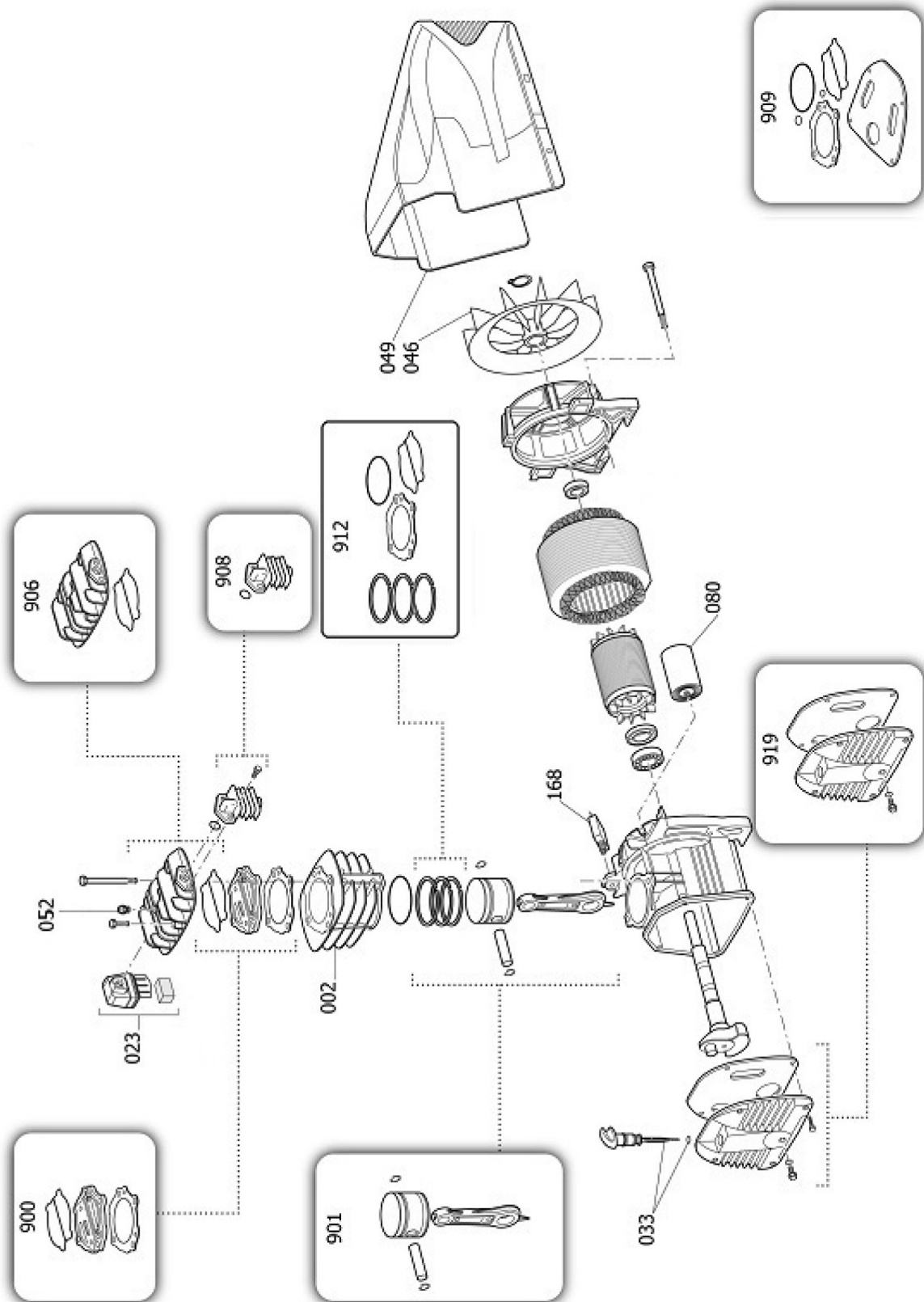

Fig. 18: Spare parts Compressor

Spare parts drawing 2: Housing

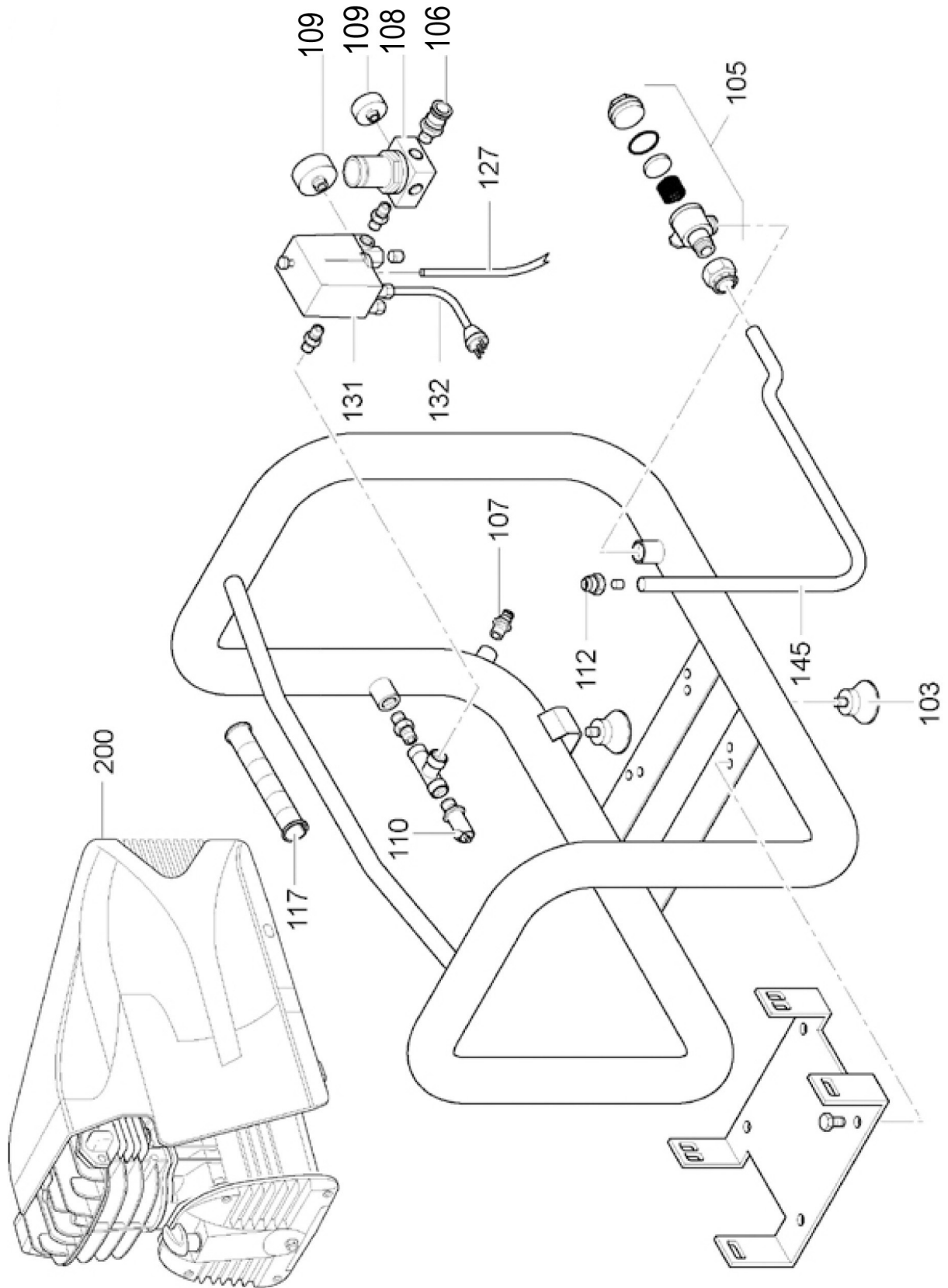

Fig. 19: Spare parts Housing

## 12 EU Declaration of Conformity

**Manufacturer/distributing company:** AIRCRAFT Kompressorenbau und Maschinenhandel GmbH  
Gewerbestraße Ost 6  
A-4921 Hohenzell

herewith declares that the following product

**Product group:** AIRCRAFT® Compressed air technology

**Type of machine:** Piston Compressor

**Description\*:** **Item number:**

AIRBOY KITT 90 2001237

AIRBOY 262 E 2001247

**Serial number\*:** \_\_\_\_\_

**Year of manufacture:** 20\_\_\_\_\_

\*please fill in according to the information on the type plate

complies with the relevant fundamental health and safety requirements of the Machinery Directive 2006/42/EC due to its design and construction, as well as in the version placed on the market by us.

With regard to pressure hazards, the relevant requirements of Directive 2014/68/EU are complied with.

<b>Applicable EU Directives:</b>	2014/30/EU	EMC Directive
	2011/65/EU	RoHS Directive
	2000/14/EG	Outdoor Directive

**The following harmonized standards were applied:**

DIN EN 55014-1:2018-08	Electromagnetic compatibility - Requirements for household appliances, electric tools and similar apparatus - Part 1: Emission
DIN EN 55014-2:2016-01	Electromagnetic compatibility requirements for household appliances, Power tools and similar electrical equipment - Part 2: Immunity - Product family standard
DIN EN 60204-1:2019-01	Safety of machinery - Electrical equipment of machines - Part 1: General requirements
DIN EN 1012-1:2011-02	Compressors and vacuum pumps - Safety requirements - Part 1: Air compressors
DIN EN IEC 61000-3-2:2019-12	Electromagnetic compatibility (EMC) - Part 3-2: Limits - Limits for harmonic current emissions (equipment input current ≤ 16 A per phase)
DIN EN 61000-3-3:2020-07	Electromagnetic compatibility (EMC) - Part 3-3: Limits - Limitation of voltage changes, voltage fluctuations and flicker in public low-voltage supply systems, for equipment with rated current ≤ 16 A per phase and not subject to conditional connection

**Responsible for the documentation:** Klaus Hütter, Gewerbestraße Ost 6, A-4921 Hohenzell

Hohenzell, 23.01.2021

Hallstadt, 23.01.2021



Klaus Hütter  
Manager



Kilian Stürmer  
Manager



